



## MASTER 3 P -COPY ROUTER

COPY ROUTER / COPY ROUTER



|   |  |
|---|--|
| Pressione d'esercizio<br>Operating pressure<br>Pression de service 6/7 Atm.<br>Betriebsdruck<br>Presion de uso              |  <b>Kg. 120</b>   |
| <b>Morsa pneumatica</b><br>Pneumatic clamp<br>Etau pneumatique<br>Pneumatische<br>Feststellvorrichtung<br>Mordaza Neumatica |  <b>El mm. 320 max.</b><br><b>Ep mm. 130 max.</b><br><b>Eh mm. 120 max.</b> |
| <b>Motore - Motor</b><br>Moteur - Motor<br>Motor<br>Giri mandarino  | <b>HP 1</b><br><b>V. 220/380</b><br><b>2800 giri</b><br><b>10000</b>   |
|                                        | <b>X mm. 720</b><br><b>Y mm. 700</b><br><b>H mm. 1450</b><br><b>Mc 0,75</b>  |

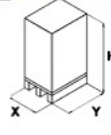

ALPTECH INTERNATIONAL

**Address:** Plot No. A/232, Road No. 21, 'Y' Lane, Wagle Estate, Thane-400 604. INDIA. | **Telephone No.:** +91 9769976747 / 22-25823203  
**Email.:** alptechinternational@gmail.com | **Web.:** www.alptechindia.com | **PAN NO.:** AARCA9816A | **GST No.:** 27AARCA9816A1ZJ

## Description:

TECHNICAL DATA -

Manual single head copy router with pneumatic clamps and lubrication, with manual tracer points. Equipped with horizontal head with 3 drilling bits for working on PVC profile. Working capacities 360x150x140mm. Spindle speed 13200 rpm. Threephase motor 1HP (0.57 Kw). Horizontal motor 0.75 HP 900 RPM (0.55 Kw). Nr 2 manual tracer points. Working pressure 7 bar. Overall dimensions: 70x110x162 cm. Weight: 160 Kg.

## Specification:

STANDARD EQUIPMENT

Bit D. 8/8mm - Collet D. 8mm - Pneumatic Clamping set - 2x tracer points with 3 diameters:  
5/8/10 mm - Copy template for standard executions - Profiles stop - Nr 2 bits D.10 - Nr 1 bits  
D.12 - Air Filter - Air Gun - Service spanners

OPTIONALS -

Collet D.10mm-AUTOMATIC FEEDING OF THE BORING UNIT-Bit D.10-Bit D.12 Bit diameter  
on request - Self centering device - Single phase motor.

**Product Code:** PRO-32

**Country:**  Italian

**HSN Code:** 0

**Unit:** 0

**Gross Weight:** 170KG

**Net Weight:** 150KG

**Dimension:** L950\*W1000\*H1900